

## Customer Check List For Proper Use Of The System

THE BARRIERS ARE NOT TO BE MARKED, LABELLED OR GENERALLY DEFACED IN ANY WAY.

### Handling

Fork lift / crane handling of the Barriers :

The barriers should only be lifted or moved by using the base of the barrier.  
( as shown below ).

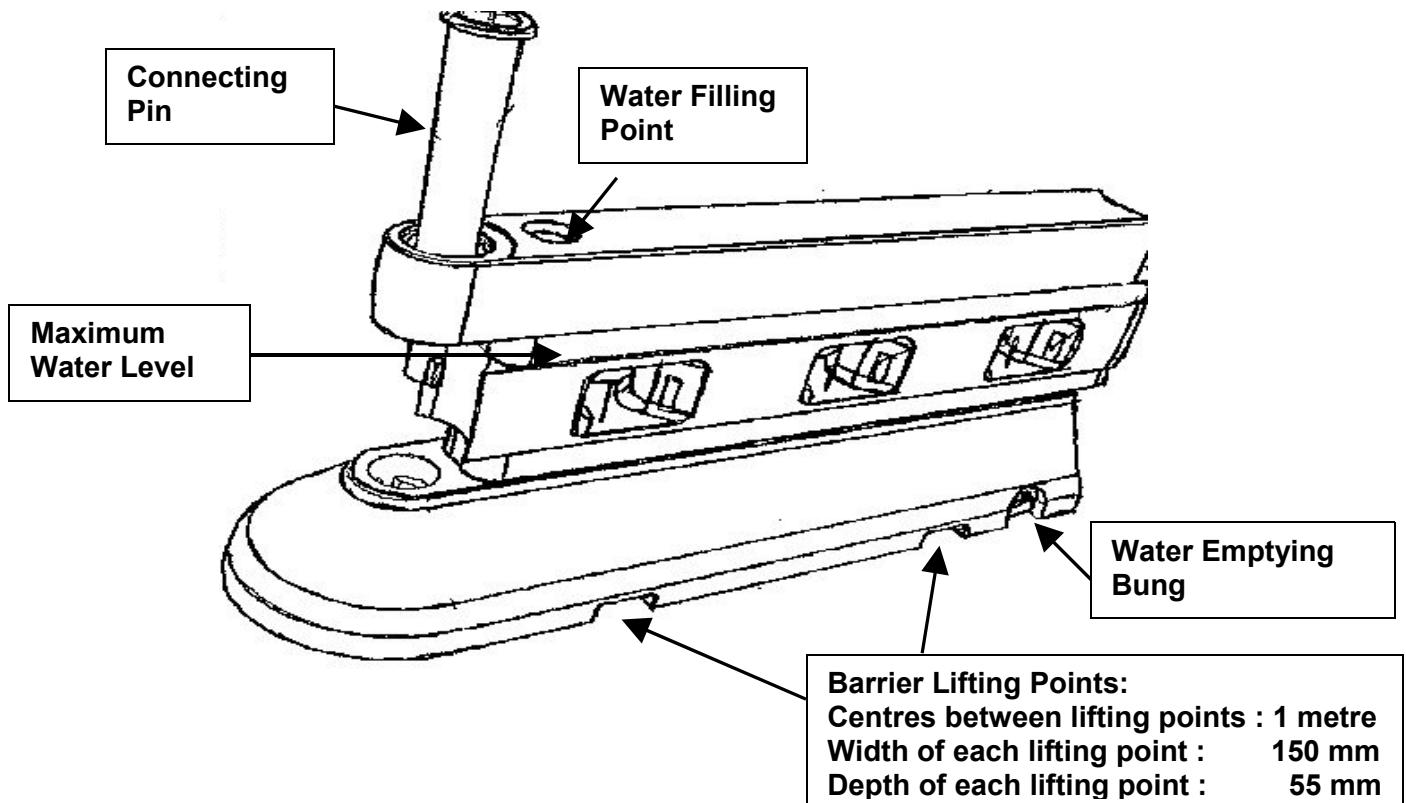

Water filled barriers can be moved one at a time.

The pin should not be removed from the barrier for unloading, positioning on site or reloading. **SAFETY GLOVES MUST BE WORN WHEN HANDLING BARRIER CONNECTING PINS**

### Installation

Check the (water release) bungs are **securely tightened** prior to water filling.

Barriers located on an incline should have the bungs on the lower side of the barrier to ensure that the water empties from the units freely.

**Ensure that all the bungs are screwed back into the barriers after the water has been emptied.**

Water filling should be completed prior to fence panels being fitted.

Anti freeze/salt solution can be added to the water in the case of extreme cold.